

ソリッドステート・タイマ

# H3CR-A-301 AC24-48/DC12-48



## 商品概要

Solid-state Timer, 11-pin, Time range: 0.1 s to 600 h, No-voltage input (NPN), Relay output (DPDT) Time-limit contact, 24 to 48 VAC/12 to 48 VDC

## 販売状況

2026/03/30 00:00 情報更新

販売状況	販売中
機種区分	受注生産機種
標準価格(税別)	¥ 5,050

推奨代替品の最新情報につきましては、当社Webサイト([www.fa.omron.co.jp](http://www.fa.omron.co.jp))の「生産終了品/推奨代替品」をご覧ください。  
在庫状況/標準価格の最新情報につきましては、当社Webサイト([www.fa.omron.co.jp](http://www.fa.omron.co.jp))の「在庫状況/標準価格照会」をご覧ください。

# 詳細情報

## Ratings/Specifications

情報更新：2024/12/23

Rated power supply voltage	24 to 48 VAC 50/60 Hz 12 to 48 VDC Ripple 20% max. (If power supply incorporates a single-phase full-wave rectifier)
Allowable voltage variable range	85 to 110% of rated voltage (90 to 110% at 12 to 48 VDC)
Input signals	Start, Reset, Gate
Input method	No-voltage input
No-voltage input	Short-circuit (ON) impedance: 1 kΩ max. Short-circuit (ON) residual voltage: 1 V max. Open circuit impedance: 100 kΩ min.
Power consumption	Relay ON: Approx. 0.8 W (at 24 VDC)/Relay OFF: Approx. 0.2 W (at 24 VDC)
Reset voltage	10% max. of rated supply voltage
Number of time ranges	18
Operation mode	ON delay, Flicker OFF start, Flicker ON start, Signal ON/OFF delay, Signal OFF delay, Interval, Signal ON/OFF delay, One shot output
Control output (Type)	Time-limit: DPDT
Control output (Contact output)	Resistive load: 250 VAC 5 A (cosφ=1)/5 A at 30 VDC/0.15 A at 125 VDC Inductive load (Reference value): 2 A at 250 VAC (cosφ=0.4)/3 A at 30 VDC (L/R=7 ms) Minimum applicable load: 10 mA at 5 VDC (failure level: P Reference value)
Operating resetting	Time-limit operation/Self-reset/External reset
Ambient temperature range	Operating: -10 to 55 °C (with no icing) Storage: -25 to 65 °C (with no icing)
Ambient humidity range	Operating: 35 to 85 %
Accuracy of operating time	±0.2% FS max. ±0.2% ±10 ms in a range of 2.4 s and 6 s
Setting error	±5% FS ±50 ms max.
Reset time	0.1 s max.
Influence of voltage	±0.2% FS max. ±0.2% ±10 ms in a range of 2.4 s and 6 s
Influence of temperature	±1% FS max. (±1% ±10 ms in a range of 2.4 s and 6 s)
Insulation resistance	100 MΩ min. (at 500 VDC)
Dielectric strength	Between current carrying metal parts and non-current carrying metal parts: 2,000 VAC 50/60 Hz 1 min Between control output terminals and operating circuit: 2,000 VAC 50/60 Hz 1 min Between contacts of different polarity: 2,000 VAC 50/60 Hz 1 min Between non-continuous contacts: 1,000 VAC 50/60 Hz 1 min

Impulse withstand voltage	Between power terminals: 1 kV Between current carrying terminals and exposed non-current carrying metal parts: 1.5 kV
Noise immunity	±1.5 kV (between power terminals) and ±600 V (between No-voltage input terminals), square-wave noise by noise simulator (pulse width: 100 ns/1 μs, 1-ns rise)
Static immunity	Multifunction: 8 kV, Destruction: 15 kV
Vibration resistance	Destruction: 10 to 55 Hz, 0.75 mm single amplitude each in 3 directions for 2 h Malfunction: 10 to 55 Hz, 0.5 mm single amplitude each in 3 directions for 10 min
Shock resistance	Destruction: 1,000 m/s <sup>2</sup> , 3 times each in 6 directions Malfunction: 100 m/s <sup>2</sup> , 3 times each in 6 directions
Life expectancy (relay output)	Electrical: 100,000 operations min. (5 A at 250 VAC, resistive load at 1800 operations/h) Mechanical: 20 million operations min. (under no load at 1,800 operations/h)
Degree of protection	Panel surface: IP40 Terminals: IP00
Connecting method	11-pin round socket
Case color	Munsell 5Y7/1
Weight	Approx. 90 g
Accessories	Instruction manual, Compliance information sheet
Applicable socket	P2CF-11/ P2CF-11-E/ P3GA-11/ PL11/ PL11-Q/ PLE11-0

## Dimensions

情報更新：2024/12/23

Outline drawing

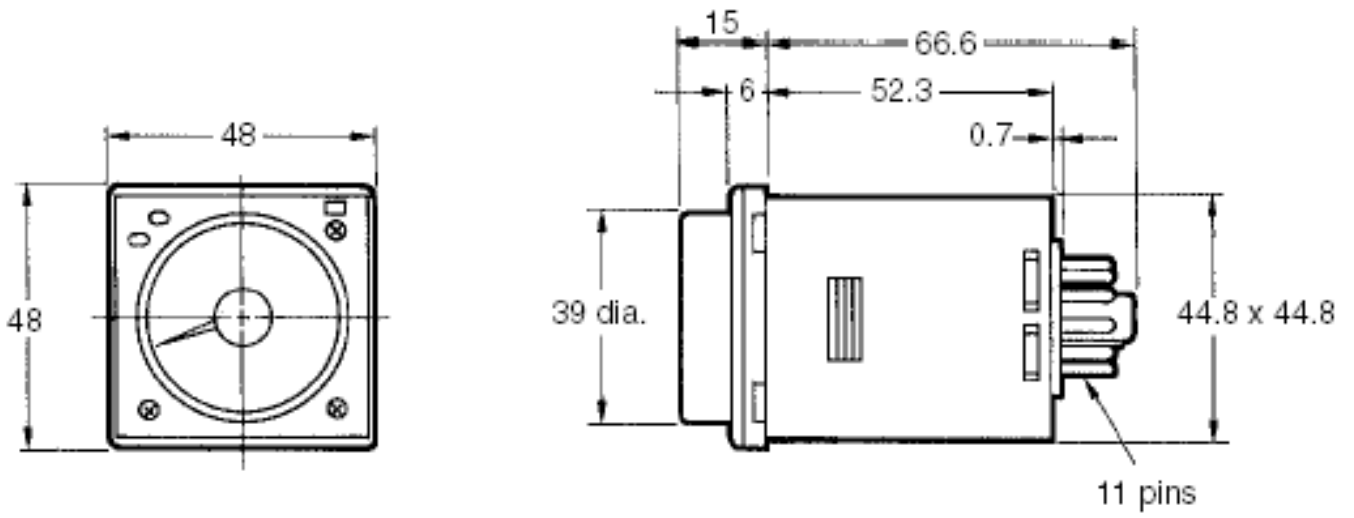

# Internal connection

情報更新：2024/12/23

Internal connection

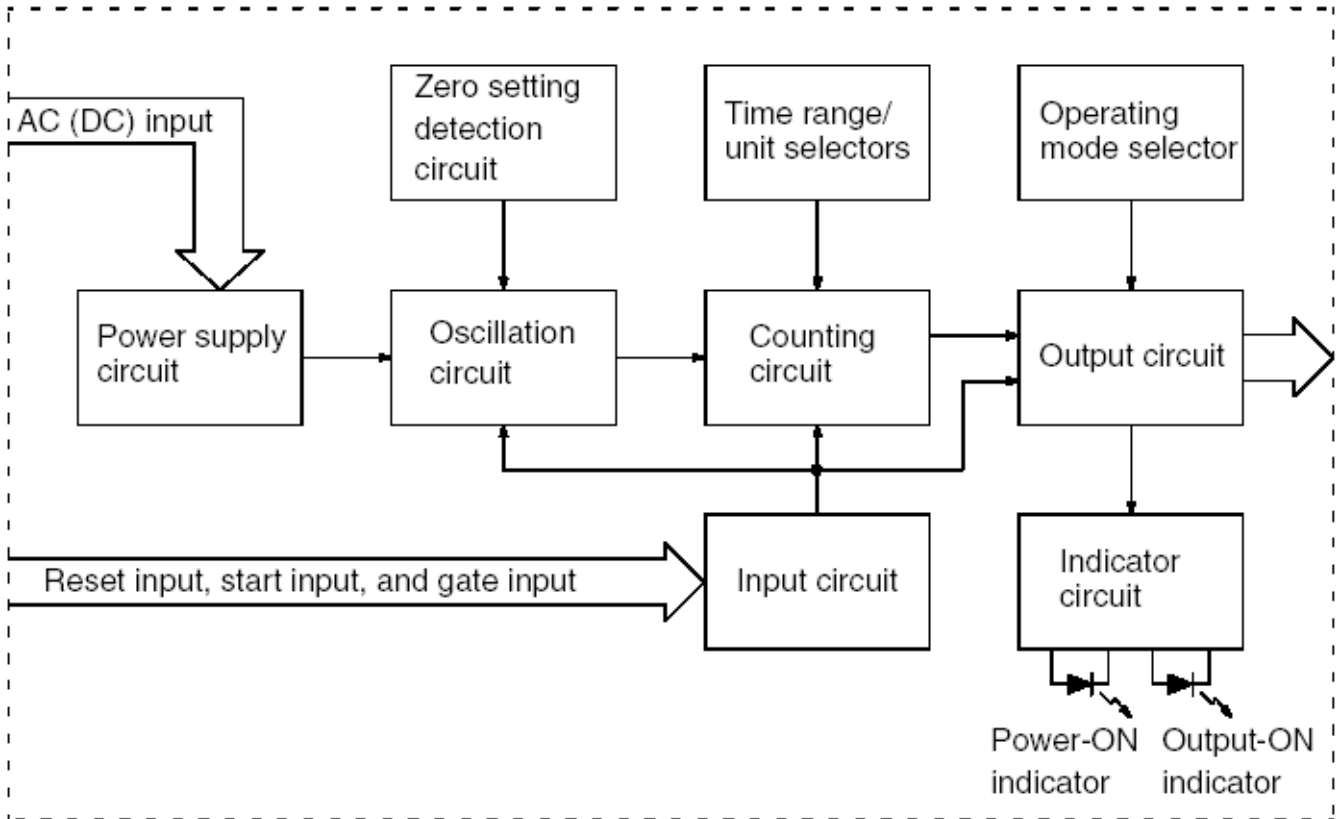

# Terminal arrangement

情報更新：2024/12/23

Terminal arrangement

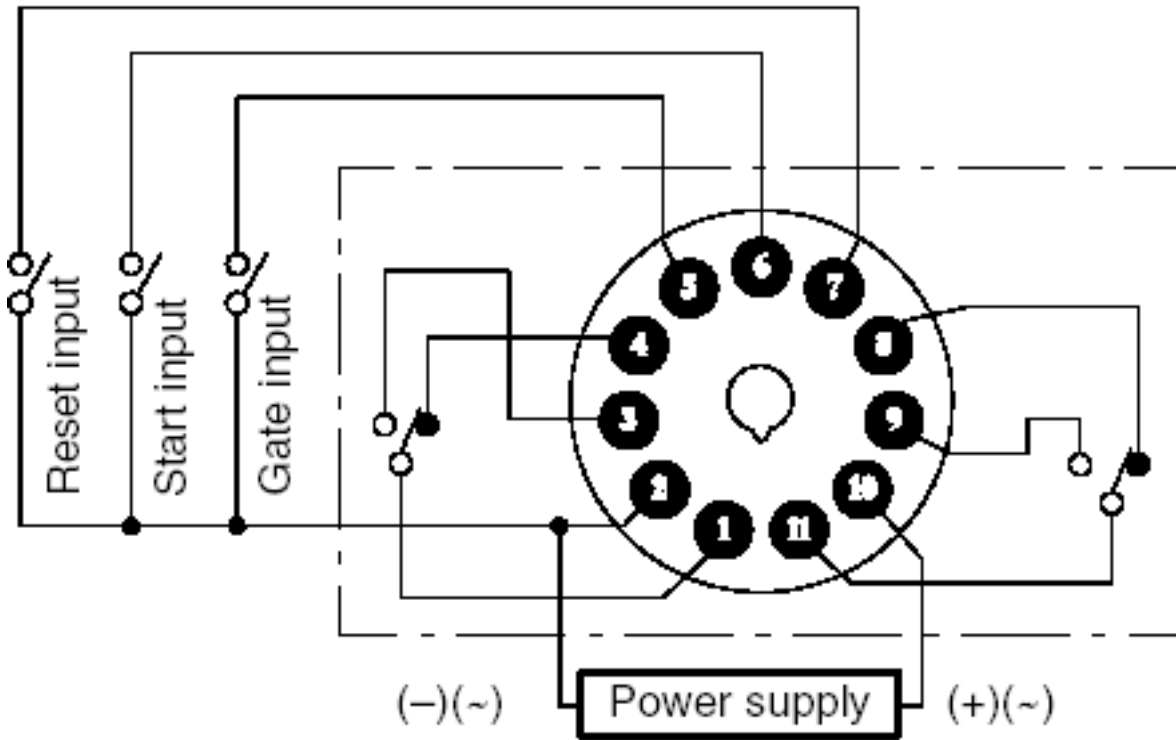

# Input connections

情報更新：2024/12/23

Input connections

## H3CR-A/-AS/-A-301

The inputs of the H3CR-A/-AS/-A-301 are no-voltage (short-circuit or open) inputs.

### No-voltage Inputs

#### No-contact Input

(Connection to NPN open collector output sensor.)

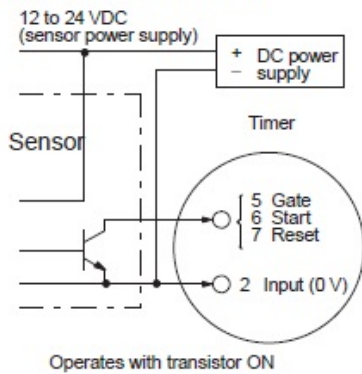

#### Contact Input

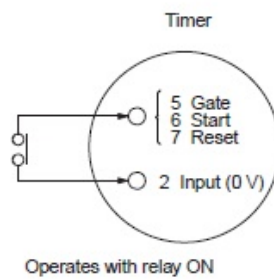

#### No-contact Input

(Connection to a voltage output sensor.)

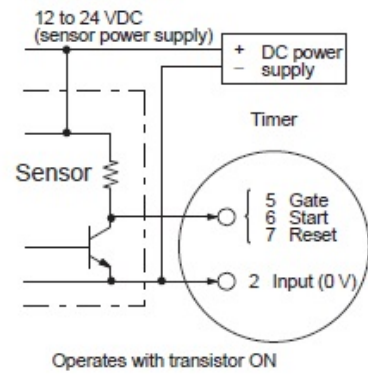

### No-voltage Input Signal Levels

No-contact input	1. Short-circuit level Transistor ON Residual voltage: 1 V max. Impedance when ON: 1 kΩ max.
	2. Open level Transistor OFF Impedance when OFF: 100 kΩ min.
Contact input	Use contacts which can adequately switch 0.1 mA at 5 V

# Time ranges

情報更新：2024/12/23

Time ranges

## Double (0.1-s to 600-h) Models

	Time unit	s (sec)	×10 s (10 sec)	min (min)	×10 min (10 min)	h (hrs)	×10 h (10 hrs)
Full scale setting	2.4	0.1 to 2.4	2.4 to 24	0.24 to 2.4	2.4 to 24	0.24 to 2.4	2.4 to 24
	6	0.6 to 6	6 to 60	0.6 to 6	6 to 60	0.6 to 6	6 to 60
	24	2.4 to 24	24 to 240	2.4 to 24	24 to 240	2.4 to 24	24 to 240
	60	6 to 60	60 to 600	6 to 60	60 to 600	6 to 60	60 to 600

**Note:** When the time setting knob is turned below "0" until the point where the time setting knob stops, the output will operate instantaneously at all time range settings.

# Operating chart

## Operating chart

情報更新：2024/12/23

Operating mode	Timing chart	
A: ON-delay		<p><b>Basic operation</b></p> <p><b>Note:</b> Start input is invalid while the Timer is in operation.</p>
B: Flicker OFF start		<p><b>Basic operation</b></p> <p><b>Note:</b> Start input is invalid while the Timer is in operation.</p>
B2: Flicker ON start		<p><b>Basic operation</b></p> <p><b>Note:</b> Start input is invalid while the Timer is in operation.</p>
C: Signal ON/OFF-delay		<p><b>Basic operation</b></p> <p><b>Note:</b> Start input is valid and retriggerable while the Timer is in operation.</p>
D: Signal OFF-delay		<p><b>Basic operation</b></p> <p><b>Note:</b> Start input is valid and retriggerable while the Timer is in operation.</p>
E: Interval		<p><b>Basic operation</b></p> <p><b>Note:</b> Start input is valid and retriggerable while the Timer is in operation. (Previous start input will be cancelled.)</p>
G: Signal ON/OFF-delay		<p><b>Basic operation</b></p> <p><b>Note:</b> Start input is valid and retriggerable while the Timer is in operation.</p>
J: One-shot output		<p><b>Basic operation</b></p> <p><b>Note:</b> Start input is valid and retriggerable while the Timer is in operation. (Previous start input will be cancelled.)</p>

**Gate Signal Input** (This timing chart indicates the gate input in operating mode A (ON-delay operation).)

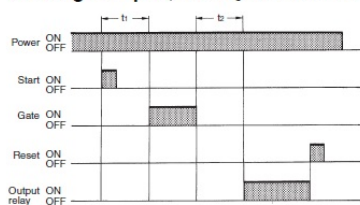

- Note:**
1. Allow at least 0.1 s for the Timer reset time if the power supply is reset due to an interruption in the power supply.
  2. The minimum input pulse width (for start, reset) is 0.05 s.
  3. The letter "t" in the timing charts indicates the set time, and "t-a" means that the period is less than the set time. (t - a < t)
  4. In J Mode, there will be only one output even if the start input is longer than the set time.
  5. H3CR-AP model incorporates start input only. As such, the power supply is reset.
  6. Model H3CR-A5 only has operation equivalent to time-limit contact: NO.
  7. When the setting dial is turned all the way past 0 for instantaneous output, "t" (set time) in the above time chart is 0-sec operation.
  8. During timer operation, the flash frequency changes when 90% of the set time has been reached.

**Note:** The set time is the sum of t1 and t2.  
Start and reset are also both enabled when the gate signal is ON.

# Electrical life curve

情報更新：2024/12/23

## Electrical life curve

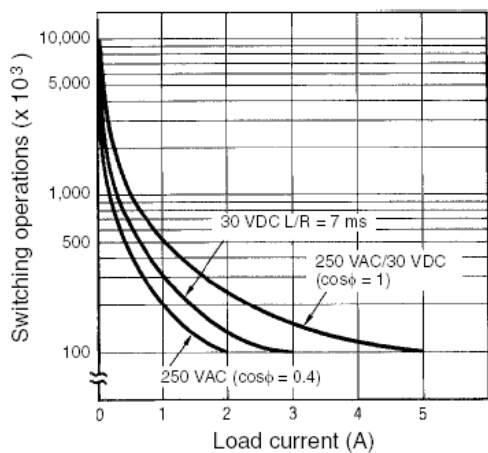

Reference: A maximum current of 0.15 A can be switched at 125 VDC ( $\cos\phi = 1$ ) and a maximum current of 0.1 A can be switched if L/R is 7 ms. In both cases, a life of 100,000 operations can be expected. The minimum applicable load is 10 mA (100 mA for H3CR-A8E) at 5 VDC (failure level: P).

## RoHS/REACH対応状況

情報更新：2026/4/15

### EU RoHS

対応状況 ※1	対応予定月 ※2	非含有証明書 ※3
 対応済み		<a href="#">ダウンロードはこちら</a>

### 中国 RoHS

中国 RoHS表 ※1※2										
Pb	Hg	Cd	Cr(VI)	PBBs	PBDEs	DBP	DIBP	BBP	DEHP	環境保護 使用期限
X	0	0	0	0	0	0	0	0	0	10

- ・“対応済み”や非含有の記載がされた商品であっても、流通在庫等で未対応品が混在する可能性があります。
- ・非含有品が必要な際は、弊社営業部門もしくは販売店へお問い合わせください。

[この製品のRoHS/REACH対応状況ページへ>](#)

## 注意事項・凡例

”対応済み”で記載される商品であっても、流通在庫等で未対応品が混在する可能性があります。  
非含有品が必要な際は、弊社営業部門もしくは販売店へお問い合わせください。

### ※1 対応状況

- ・  対応済み : EU RoHS指令（10物質）の非含有に対応した製品が提供可能な商品です。
- ・ 対応予定 : EU RoHS指令（10物質）の非含有に対応した製品に切り替える予定のある商品です。
- ・ 対応予定なし : EU RoHS指令（10物質）の非含有に非対応の商品で、対応品を出す予定はありません。
- ・ 調査・確認中 : EU RoHS指令（10物質）の非含有の対応状況を調査中または確認中の商品です。
- ・ 非該当品 : ライセンス料など無形物で、有害物質有無と関係のない商品です。

仕入先様の事情により、非含有部品としていたものが、含有品と判明した場合などやむを得ず変更することがあります。

\* EU RoHS指令（10物質）：

鉛(Pb) 1000ppm以下、水銀(Hg) 1000ppm以下、カドミウム(Cd) 100ppm以下、六価クロム(Cr(VI)) 1000ppm以下、  
ポリ臭化ビフェニル類(PBB) 1000ppm以下、ポリ臭化ジフェニルエーテル類(PBDE) 1000ppm以下、  
フタル酸ビス(2-エチルヘキシル) (DEHP)(別名：DOP) 1000ppm以下、フタル酸ブチルベンジル (BBP) 1000ppm以下、  
フタル酸ジブチル (DBP) 1000ppm以下、フタル酸ジイソブチル (DIBP) 1000ppm以下  
但し、RoHS指令で産業用監視および制御機器に対する適用除外項目は除く。  
フタル酸エステル類の4物質については閾値を超える意図的な使用がないことを確認しています。

### ※2 対応予定月

部品在庫の切り替え状況などにより、予定月が前後することがあります。

### ※3 非含有証明書ダウンロード

下記の非含有証明書をダウンロードすることができます。

- ・ EU RoHS指令（10物質）の非含有証明書
- ・ 49物質の非含有証明書（当社基準）

※ 本証明書は発行日時時点で非含有を証明するもので、過去に遡って非含有を証明するものではありません。

また、RoHS指令のフタル酸エステル類4物質の対応では、対応完了までの期間は出荷製品に未対応品が混在することから備考欄に  
対応日を記載しておりました。

既に当社にて対応品への在庫切替を完了していることから、特段のことがない限り、2022年1月12日より割愛しております。

## 規格認証/適合状況

UL認証	CSA認証	CEマーキング適合	CCC認証	電波法
Yes	Yes	Yes	Yes	N/A

LR型式承認 (イギリス 船舶規格)	DNV型式承認 (ノルウェー 船舶規格)	BV型式承認 (フランス 船舶規格)	KR型式承認 (韓国 船舶規格)	NK型式承認 (日本 船舶規格)	ABS型式承認 (アメリカ 船舶規格)
Yes	No	No	No	Yes	No

[この製品の規格認証/適合状況ページへ>](#)  
[その他の認証はこちらのページからご検索ください>](#)